

#4 Reducing clearances with heat shields

WHAT ARE CLEARANCES?

Clearances represent the minimum distance that a woodburning appliance can be installed from anything that could overheat and potentially burn. Clearances are discussed in WISE fact sheet #3. The closer you are to a fire, the more intense the heat will be. Think about standing in front of a bonfire: if you stand too close, the heat is unbearable. You have to either step back to put distance between yourself and the fire, or put your hands in front of your face to provide a shield. The same principle applies to protecting combustible materials from the heat produced by woodburning appliances. You can either put a generous clearance distance between the appliance and combustibles, or you can install an air-cooled radiation shield or a certified commercial shield to protect the combustibles. The required clearance distances for certified appliances are given on the appliance labels and in the instruction booklets. Uncertified appliances with no shielding require clearances as great as 1200 mm (48 in.) to the front, sides and rear, and can easily occupy more than half the width of a room! Using properly installed heat shields, you can reduce the amount of space your woodburning appliance occupies.

The approach to clearance reduction is the same for certified and uncertified appliances. Before using shielding to reduce clearances for certified appliances, check the label and installation manual for instructions. It's also a good idea to talk to a WETT-certified professional before getting started.

Don't Live in Fear!

You'd be surprised how many people live in fear of their woodburning appliances. They're afraid to leave the house until the fire has died down completely. These people know instinctively that there's something not quite right about the way their appliance is installed, but they don't do anything to improve it. Instead, they worry - and worry, and worry.

Don't let this happen to you! Have your appliance installation inspected by a WETT certified professional to make sure it's safe. In most cases, the simple addition of proper shielding can ensure worry free enjoyment of your wood heating appliance. Don't be shy - check into shielding today!

WHAT'S A "COMBUSTIBLE"?

A combustible is anything that will burn, including wallpaper, wood studs, certain types of insulation (e.g., polystyrene), and paneling. Even so-called "fire-resistant" gypsum board (drywall) panels are considered combustible.

Even if a wall has a non-combustible surface of tile or brick, it is still considered combustible if this surface is mounted on combustible material such as gypsum board and wood studs. Only a wall of concrete or brick without wood behind it, or one made of metal studs with a totally non-combustible covering, can be considered non-combustible.

Wood exposed to temperatures as low as 120°C (250°F) over a prolonged period of time will begin to char and may ultimately ignite. The highest temperature to which combustibles can safely be exposed for long periods is 90°C (190°F).

Virtually all the woodburning appliances now on the market have been tested and "certified" or "listed" by one of three recognized testing and certification agencies:

- the Canadian Standards Association (CSA),
- Underwriters' Laboratories of Canada (ULC),
- Warnock Hersey Professional Services



Look for one of these logos on the label of a certified appliance

A certified appliance will be labeled as such: a product is not considered certified unless the label is attached. The label and installation manual of a certified appliance contain the clearance information needed for safe installation.

SHIELDING FOR SAFETY

Air-Cooled Radiation Shields

Clearances are designed to keep combustible materials around a woodburning appliance below 90°C (190°F), even during a chimney fire. It is possible to build an air-cooled radiation shield, which can reduce clearances because moving air is a very effective cooler.

When radiation from an appliance hits a shield and heats it, the shield in turn heats the air behind it. Since hot air rises, the air moves up and exits through spaces at the top of the shield, and cooler air is drawn in at the bottom of the shield to replace it. The hotter the shield gets, the faster the heated air rises, and the more air passes by the shield, cooling it down.

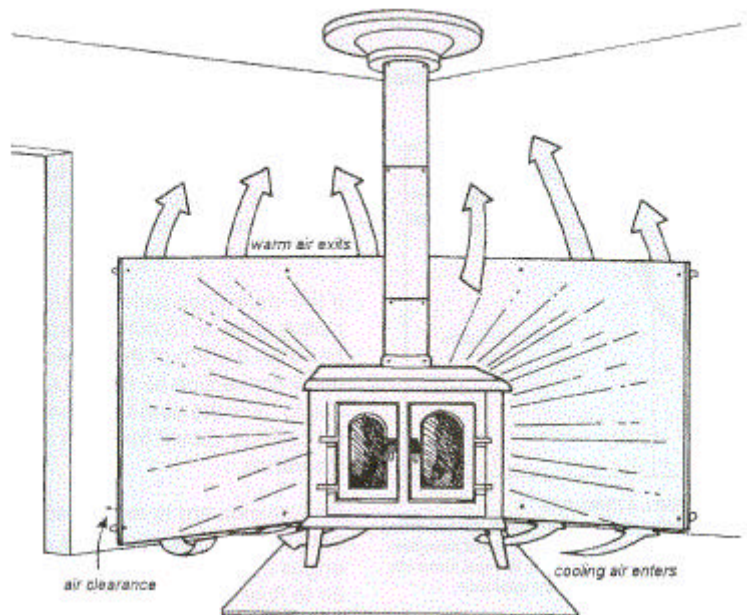

A shielding system made of small sheet metal panels is less likely to buckle than one made of a single large sheet. The edges of the metal should be hemmed to improve its strength and appearance. This kind of system is inexpensive and easily adapted to many situations.

Wall shields must extend at least 450 mm (18 ") beyond each edge of the appliance and 500 mm (20") above the appliance. To allow air to flow behind the shield, there must be a space of at least 25 mm (1 in.) at the bottom of the shield and a 21 mm (7/8 in.) space between the shield and the wall. (If the shield must extend up the wall to shield the flue pipe, a 75 mm (3 in.) space must be left at the top so the cooling air can escape.) The shield should be permanently mounted on the wall using screws through non-combustible spacers.

Air-cooled shields for ceilings should have a 75 mm (3 in.) clearance from adjacent walls.

Certified Commercial Shields

If you do not want to build an air-cooled radiation shield, several different styles of metal and brick or stone commercial shields are available. Be sure that any commercial shield you buy has been certified and labeled by one of the three recognized testing agencies. The manufacturer's instructions will specify how to install the shields, and the clearance reductions that can be achieved.

What Can Shields Be Made Of?

- Sheet metal with a minimum thickness of 0.33 mm (0.013 in.). This is only 30 gauge -26 gauge is better. The edges should be hemmed (safety edge).
- A solid brick wall at least 21 mm (7/8 in.) away from the wall and vented at the top and bottom.
- Brick or tile slices mounted on an approved non-combustible board with a 21 mm (7/8 in.) air space behind it.
- A certified commercial shielding system.

Ask a WETT certified professional for advice

Brick ties spaced on 400 mm (16") centers are needed to support brick shields. They should be anchored firmly into framing studs. The top course of brick can be set on its narrow edge to give the minimum

75 mm (3") edge clearance. This type of shield provides for a 50% Clearance reduction

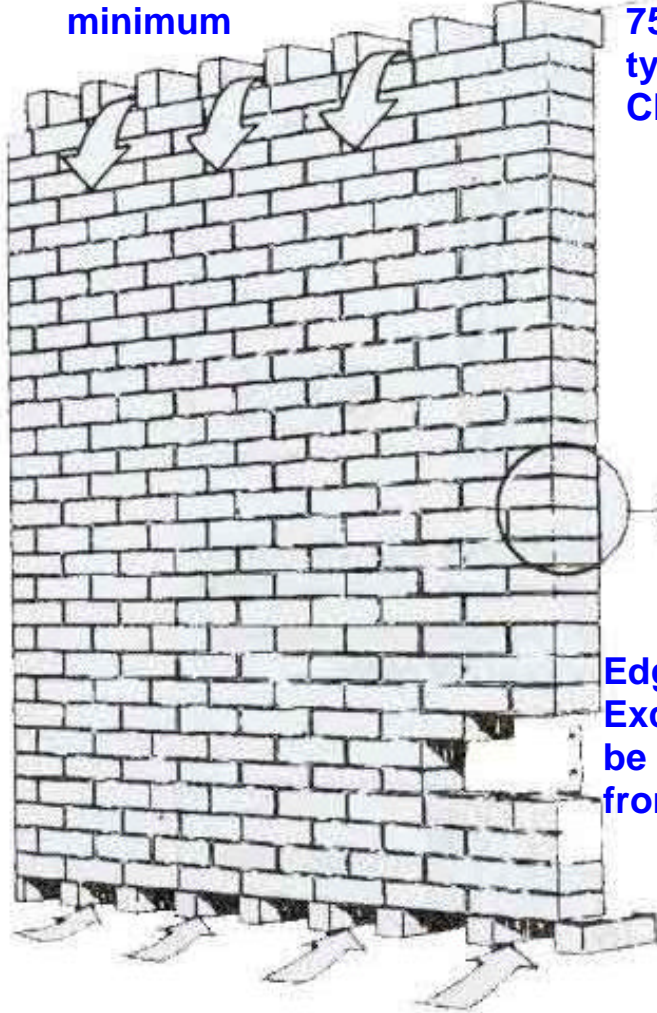

Edge View

Excess mortar should be removed (or struck) from behind the bricks.

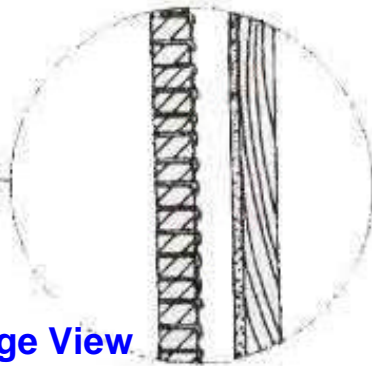

Steel backing for a brick shield should rest on the bottom course of bricks to ensure airflow behind the shield. If spacer channels rest on the floor or on the bottom course of bricks, be sure to ventilate them at the bottom so that air can flow through the channel. This type of shield construction provides for a 67% clearance reduction.

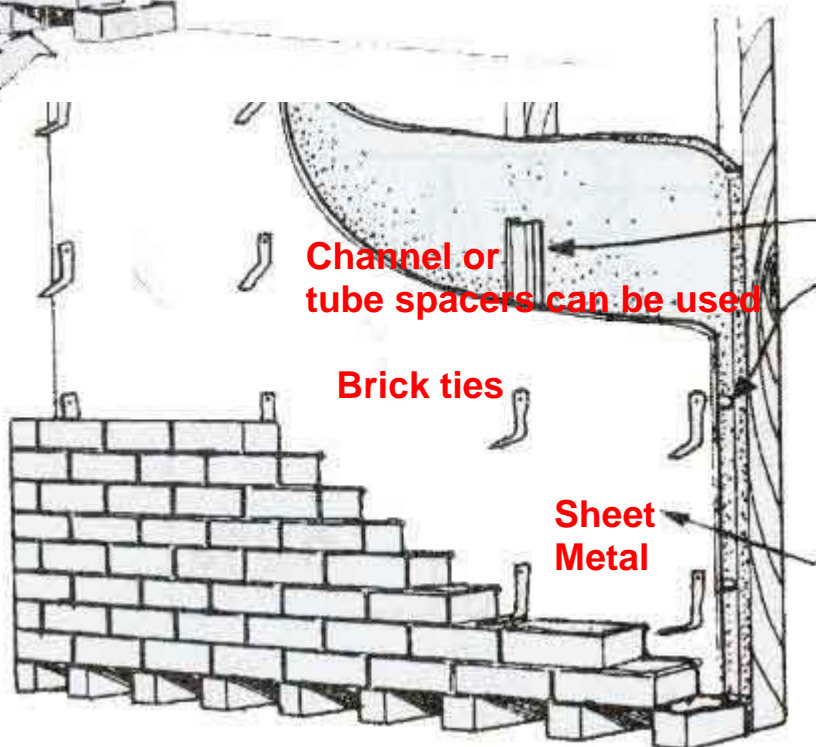

Various combinations of sheet metal, brick and tile can reduce required clearance by either 50% or 67%



Brick shields without steel backing give only a 50% reduction in clearance. Shields constructed of tile on noncombustible board also give a 50% clearance reduction

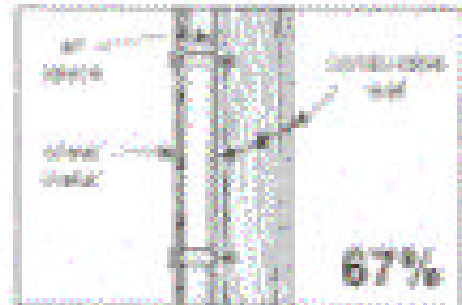
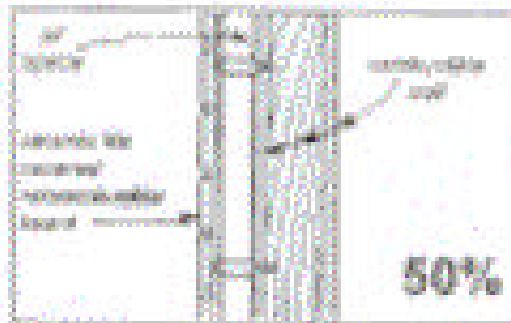

Sheet metal shields or those backed with sheet metal give greater reductions in clearance because of their ability to conduct heat rapidly across their surface reducing the intensity of hot spots.

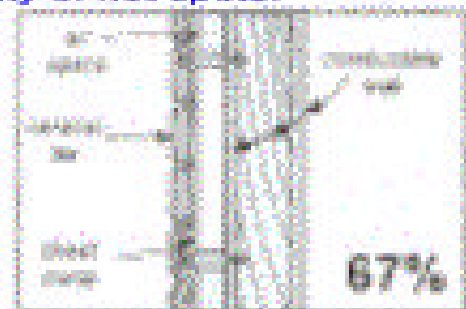

Sheet metal shields with 21mm (7/8") air space behind give a 67% reduction in the minimum clearance. Brick or tile shields backed with sheet metal also give a 67% reduction in clearance.

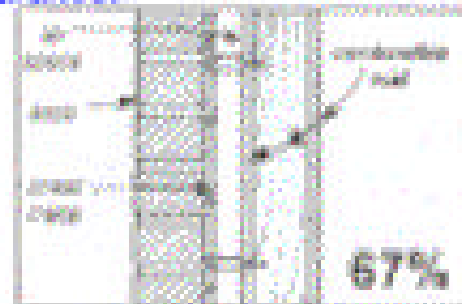

Single-wall flue pipe clearances.

- A) Minimum flue pipe clearance to unprotected combustibles 450 mm (18").
- B) Minimum flue pipe clearance to combustibles protected by a wall-mounted shield 225 mm (9").
- C) Minimum flue pipe clearance to combustible material protected by a curved shield mounted to the flue pipe 225 mm (9").

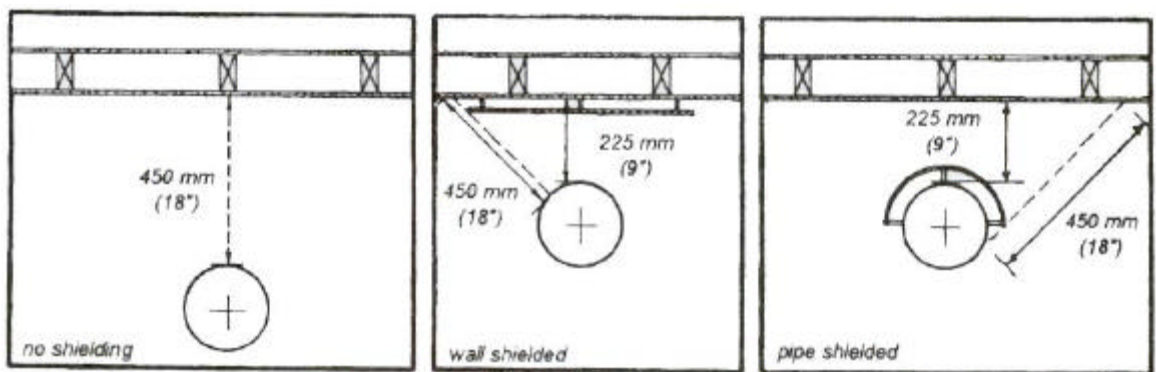

Certified double-wall flue pipes are another option: these incorporate built-in shielding. Ask a WETT-certified professional for more information about how double-wall pipes can reduce clearance requirements.

This fact sheet is intended only to provide an introduction to the topic of "Reducing clearances with heat shields" not a "how to" manual! Be sure to consult a WETT certified professional for more detailed information and explanations.

The WISE Fact sheet Series

1. Is Your Wood Heat Installation Safe?
2. Space Heating With Wood
3. Appliance and Flue Pipe Clearances
4. Reducing Clearances With Heat Shields
5. Chimneys
6. Flue Pipes
7. Operating Your Appliance ...Safely
8. Maintaining Your Heating System
9. Fireplaces
10. Fireplace Inserts
11. Purchasing, Processing and Seasoning Wood
12. Central Heating With Wood

WISE is supported by:

- Ministry of the Solicitor General
- Ministry of Housing
- Ministry of Energy Ontario
- Ministry of Consumer and Commercial Relations

Wood Energy Technical Training (WETT)

The Wood Energy Technical Training Inc, is a non-profit, educational institution established in 1988. Provincial affiliates of WETT Inc are dedicated to chimney and venting system safety, and to the elimination of residential chimney fires, carbon monoxide intrusion and other chimney related hazards that result in the loss of lives and property. WETT devotes its resources to educating the public, chimney service professionals, and other fire prevention specialists about the prevention and correction of chimney and venting system hazards.

WETT has developed a training and certification program for wood heat appliance installers, inspectors, chimney sweeps and other professionals called the "Wood Energy Technical Training" (WETT) program. Be sure that any wood heat professional you consult is WETT certified. Look for the WETT logo, it's your best guarantee of reliable advice. For additional information, contact:

Wood Energy Technical Training Inc at 1-888-358-9388 or fax at 1-416-968-6818 or email at info@wettinc.ca

The local British Columbia affiliate is the Wood Energy Technicians of British Columbia, aptly named "**WETBC**". They can be reached at zigi@shaw.ca or phone/fax is 1-604-941-4172. Our web site is at www.wetbc.ca

WETT Your Assurance of Reliable Advice