

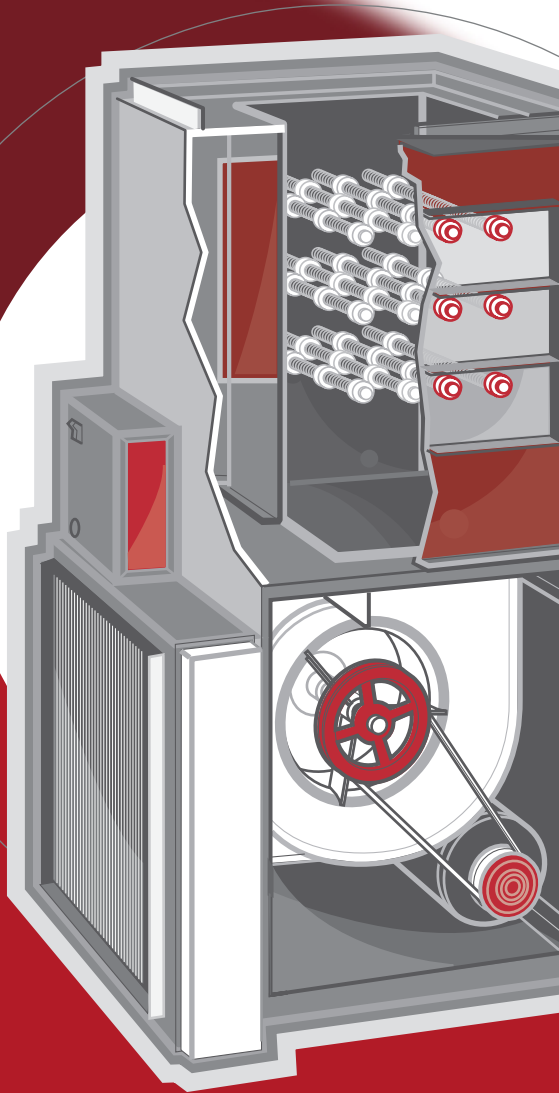

# Heating With Electricity



Natural Resources  
Canada

Ressources naturelles  
Canada

Canada



## **Heating with Electricity**

Produced by the  
Natural Resources Canada's  
Office of Energy Efficiency  
**EnerGuide**

The Heating and Cooling Series is published by Natural Resources Canada's Office of Energy Efficiency's EnerGuide programs. EnerGuide is the official Government of Canada mark associated with the labelling and rating of the energy consumption or energy efficiency of household appliances, heating and ventilation equipment, air conditioners, houses and vehicles.

EnerGuide also helps manufacturers and dealers promote energy-efficient equipment and provides consumers with the information they need to choose energy-efficient residential equipment.

**The National Library of Canada has catalogued this publication as follows:**

Main entry under title :

Heating with electricity

(Home heating and cooling series)

Issued also in French under title: Le chauffage à l'électricité.

ISBN 0-662-33774-3

Cat. no. M91-2/119-2003E

1. Electric heating – Handbooks, manuals, etc.
  2. Dwellings – Heating and ventilation – Handbooks, manuals, etc.
  3. Dwellings – Energy conservation.
- I. Canada. Natural Resources Canada.

TH7410.H52 2003

697.045

© Her Majesty the Queen in Right of Canada, 2003

Revised March 2003

Aussi disponible en français sous le titre :

*Le chauffage à l'électricité*

To receive additional copies of this publication, write to:

Energy Publications

Office of Energy Efficiency

Natural Resources Canada

c/o S.J.D.S.

Ottawa, Ontario K1A 1L3

Facsimile: (819) 779-2833

Toll-free: 1 800 387-2000

You can also view order several of the Office of Energy Efficiency's publications online. Visit our Energy Publications Virtual Library

at <http://oee.nrcan.gc.ca/infosource>

The Office of Energy Efficiency's web site is <http://oee.nrcan.gc.ca>



Printed on  
recycled paper



## Table of Contents

<b>Introduction</b>	.....	2
<b>Chapter 1</b>	The Four-step Decision-making Process for Home Heating .....	6
<b>Chapter 2</b>	Basic Equipment for Electric Heating Systems .....	16
<b>Chapter 3</b>	Comparing Annual Heating Costs .....	34
<b>Chapter 4</b>	Accommodating the Electrical Load ...	39
<b>Chapter 5</b>	The Mechanics of Buying, Installing and Maintaining a System .....	41
<b>Chapter 6</b>	Electric Water Heaters .....	47
<b>Chapter 7</b>	Need More Information? .....	50

# HEATING WITH ELECTRICITY

## Introduction

If your present home heating system is too expensive to operate, is in poor condition, or if you are planning on buying a new home, you are probably considering your heating options. About 60 per cent of the energy required to run the average home is used for space heating. Therefore, one of the most important projects you will undertake as a homeowner, besides insulating and draftproofing, is choosing, replacing or improving your heating system. A wise decision about heating can significantly reduce your heating costs while also making your home more comfortable. Some very impressive technological innovations have been made in heating systems in recent years, and there is a wide range of good equipment on the market.

You will be using your new or improved heating system for a long time, so it is important to do some research before deciding. It is worth taking the time to ensure that you make the best choice for your situation by first thoroughly investigating all your options. Nowadays, however, your options may be quite bewildering, because of the wide range of equipment and energy sources available. This booklet will undoubtedly help you in your decision-making process, whether you are installing a system in a new home, replacing a system in an existing home, or simply considering upgrading your present system.

## How to Use This Booklet

To simplify the process, we have identified four interrelated steps for making your home heating decisions:

**Step 1:** Draftproofing and insulating

**Step 2:** Selecting your energy source

**Step 3:** Selecting or improving your heat distribution system

**Step 4:** Selecting your heating equipment

Each of these steps and the various options are discussed briefly in Chapter 1 on page 6. The remainder of this booklet focuses entirely on **heating with electricity**. If you decide to use a **heat pump**, refer to the booklet entitled:

- *Heating and Cooling with a Heat Pump*

If you decide to use **oil**, **natural gas** or **wood**, refer to the other companion booklets in this series entitled:

- *Heating with Oil*
- *Heating with Gas*
- *A Guide to Residential Wood Heating*
- *All About Wood Fireplaces*

These publications are available from Natural Resources Canada (NRCan) or from your local electrical or gas utility, or fuel oil supplier. Refer to page 52 for information on how to order them.

How you use this booklet will be determined largely by where you are in your decision-making process:

- *If a new house is being built for you, you may have ALL the steps and options open to you (Steps 1 through 4).*
- *If you already own your home but are considering replacing an existing heating system, MANY of the steps and options may interest you — particularly if you have a variety of fuel/energy choices in your area (Steps 1 through 4).*
- *If you already have a satisfactory heat distribution system, either forced-air or hot-water (also called hydronic), and are interested only in upgrading it (Step 3) and reducing your heating bill, then your options are switching energy sources (Step 2), selecting higher efficiency equipment, or upgrading and adding equipment to your current heating equipment (Step 4). You may also decide to insulate and draftproof (caulk and weatherstrip) your house (Step 1).*
- *If you are satisfied with your existing heat source, then you should still look at Steps 1, 3, and 4.*

Before proceeding any further, you should familiarize yourself with a number of basic concepts that will help you understand your options.

## Basic Concepts

### Energy Efficiency

Electric space heating equipment that uses **electric resistance heating** is typically 100 per cent efficient because all of the electrical energy used is converted into heat and there are no combustion losses through the chimney.

Fuel-burning systems (natural gas, oil, propane, wood) lose heat for various reasons: transient operation, cold start-up, incomplete combustion, heat carried away in the combustion gases, and warm house air that is drawn up the chimney. The extent of these heat losses determines the efficiency of the furnace or boiler, given as a percentage indicating the amount of original heat that actually warms the house.

**Steady-state efficiency** measures the maximum efficiency the furnace or boiler achieves after it has been running long enough to reach its peak operating temperature. This is an important standardized testing procedure that is also used by a serviceperson when adjusting the heating system, but the figure it provides is not the efficiency the equipment will achieve in actual use over the course of a heating season. This is much like the difference between the fuel consumption figures published for cars and the actual consumption the car will achieve in its day-to-day performance.

**Seasonal efficiency** takes into consideration not only normal operating losses, but also the fact that most heating equipment rarely runs long enough to reach its steady-state efficiency temperature, particularly during the milder weather at the beginning and at the end of the heating season. This figure, known as the **Annual Fuel Utilization Efficiency (AFUE)**, is most useful to a homeowner, because it is a good indication of how much annual heating costs will be reduced by improving existing equipment or replacing it with a higher efficiency unit. (See **Table 2: Typical Seasonal Efficiencies and Energy Savings for Various Heating Systems**, p. 36).

All types of heating systems come complete with their own jargon. If you are heating with electricity or are considering it, the better you understand the electric heating jargon, the better equipped you will be to make a wise heating system choice. The text box “Coming to Terms with Electricity” presents some of the basics.

## Coming to Terms with Electricity

### Measuring up

Here are some common terms you will come across while exploring the option of heating with electricity.

**watt (W)** – The watt is the basic unit of measurement for electric power. The heating capacity of electric heating systems is usually expressed in *kilowatts* (kW). One kW equals 1000 watts.

**kilowatt hour (kWh)** – One kWh is the amount of electric energy supplied by one kW of power over a one-hour period. When converted to heat in an electric resistance heating element, one kilowatt an hour produces 3.6 megajoules (MJ) or 3412 British Thermal Units (Btu) of heat.

**ampere (A)** – Electric flow is called current and is expressed in amperes. The short form is A, although amp is also used.

**volt (V)** – A volt is the basic unit of measurement for voltage or potential difference. Voltage causes an electric current to flow.

### Putting it all together

A watt is the power you get when one volt of potential difference pushes one ampere of current.

### Expressed mathematically

Wattage = voltage x amperes ( $W = V \times A$ )

### Certification and standards

All electric heating equipment, heating elements, and electric baseboard heaters sold in Canada must meet strict manufacturing and installation standards for electrical safety. The standards fall within the purview of provincial safety codes and the Canadian Standards Association (CSA). Before purchasing your heating equipment, be sure it carries a CSA, CGA, IAS, ULC or Warnock Hersey certification label.

Federal or provincial energy efficiency standards are now in place for space heating equipment. To date, there are no standards that apply to electric resistance heating equipment; only heat pumps are affected. (*See page 16 for more details on energy efficiency standards.*)

No matter how you are heating your home, you can probably improve the efficiency of your heating system. Some of the improvements are simple enough to do yourself; others require changes that should only be done by specialized technicians, a qualified heating contractor or, in the case of electric systems, by an electrician. All improvements should be effective and provide a return on investment within a reasonable period.



# 1. THE FOUR-STEP DECISION-MAKING PROCESS FOR HOME HEATING

In this Chapter, we will describe in detail each of the four steps in the decision-making process for home heating.

## Step 1. Draftproofing and Insulating

It may be counter-productive to invest in a new or improved heating system, only to allow much of its heat to escape to the outdoors, due to an inefficient house envelope which needs more insulation or has many air leaks. To avoid this, take a look at where you can draftproof and insulate simply and effectively, **before** having a heating system sized, installed or upgraded.

There are many advantages to draftproofing and insulating. Heating the house will cost considerably less, and you will be more comfortable because of fewer drafts and warmer surfaces, such as walls. Your house will also tend to be cooler in the summer. Another benefit to draftproofing and insulating relates to humidity levels. Dry air in a house during the winter is caused by too much outside air getting in. Although the relative humidity may be high for cold outside air, the absolute amount of moisture or water vapour this cold air can hold is actually very low. When this air is brought inside and heated to room temperature, it becomes extremely dry.

If the air inside your house seems too dry, one of the simplest solutions is to add moisture, using a humidifier or an evaporator tray. However, the best way to increase humidity levels and lower heating costs is to reduce air leakage. In general, most airtight houses do not need a humidifier—the moisture generated through cooking, bathing, dishwashing, and other activities, is more than adequate.

However, with an airtight house, the reverse can occur. Making your house more airtight can affect the air quality inside. Unwanted fumes, odours, gases and too much humidity can be trapped **inside** the house envelope. One of the best ways to solve this problem is to install a fresh air intake or mechanical ventilation system that brings in and circulates fresh air, without causing drafts. Your serviceperson should be able to provide you with more information.

Insulating, caulking, and weatherstripping will reduce the amount of heat needed to keep your house comfortable. If your home has not been thoroughly reinsulated and draft-proofed, you should consider doing it **before** changing or modifying the heating system. For more information about draftproofing and insulating, order a free copy of *Keeping the Heat In* (see page 52). Whether you plan to do the work yourself or hire a contractor, this publication explains the details (including proper insulation levels) and can help make the whole job easier.

To ensure that you get a heating system with the right heating capacity, be sure to draftproof and insulate **before** you and your contractor determine what size of heating system and equipment is best. In general, oversized furnaces will waste fuel unnecessarily, because they tend to operate in frequent, short cycles. They may also decrease comfort because of the resulting excessive temperature fluctuations.

If you are buying or building a new house, insist on the R-2000 standard. R-2000 Homes have high levels of insulation, airtight construction, heat-recovery ventilators, energy-efficient windows and doors, efficient heating systems, and other design features that cut heating requirements by an average of 25 per cent compared with conventional construction. The house is more comfortable to live in, and a high quality product is ensured. For more information on R-2000 Homes, see page 51 or contact your provincial Homebuilders' Association.

## **Step 2. Selecting Your Energy Source**

The next step is to select the heating energy source that is right for you. Generally, your options include natural gas, oil, propane, electricity, or wood. You may also choose a combination of these conventional energy sources or alternatives, such as solar energy. Your decision regarding the most appropriate energy source should be based on a number of considerations, the most important of which are described below:

### **ENERGY AVAILABILITY CONSIDERATIONS**

Not all energy sources are available in all areas of Canada. Electricity and heating oil are generally available in most places, but natural gas, which must be delivered by pipeline,

is not available in much of the Atlantic region or in many rural and remote areas of other provinces. Propane is available in most parts of Canada and may be used in rural or cottage areas as a substitute for natural gas or fuel oil, although often at a significantly higher cost. In many areas, wood is a cost-effective complement to your conventional heating system. Check with your local fuel supplier, gas or electrical utility to find out which energy sources are available in your area.

## COST CONSIDERATIONS

For most homeowners, the major factor in the home heating decision is cost. This particular factor consists of two major components—the capital cost of the installed heating system and the annual operating cost for energy. Other factors, such as maintenance costs, cleanliness, and noise of operation, should also be considered.

Some of the major **installation capital costs** of different heating systems, depending on whether they are new or retrofitted, include such items as:

- hookup to gas lines or electric power lines
- cost of 200-amp service for electric heating
- storage tanks for oil or propane
- heating equipment (furnace, boiler, baseboard heaters, heat pump, etc.)
- chimney or venting system (if required)
- ducting system or pipes and radiators
- thermostats and controls
- cost of trenching or drilling for earth-energy systems (ground-source heat pumps)
- labour for installation of any of the above items.

The capital cost of a heating system can range from as low as \$1,000 for baseboard heaters in a small house to as high as \$12,000 or more for a ground-source heat pump for a larger home which is capable of providing heating, air conditioning, and hot water. Heating contractors or utility representatives can give you an estimate of the capital cost of various systems. Always ask for a firm quote before you authorize any work.

The apparently inexpensive initial cost of electric baseboard heating has resulted in the majority of electrically heated homes in Canada being of this type. Today, with much higher electricity rates, the annual cost to heat such a home has become quite high. Once installed, it is fairly difficult and costly to convert to a different energy source and heat distribution system.

The **operating or fuel cost** of a heating system is determined by the following three major factors:

1. *The heating load or heating requirements of the house.* This depends on climate, size and style of house, insulation levels, airtightness, amount of useful solar energy through windows, amount of heat given off by lights and appliances, thermostat setting, and other operational factors. Together, these factors determine the amount of heat that must be supplied by the heating system over the heating season. This number, usually expressed as Btu, kWh or MJ per year (see page 35), can be estimated by a competent heating contractor, homebuilder, or utility representative.
2. *Choice of energy source and its unit price.* Each energy source is measured and priced differently. Electricity is priced in cents per kilowatt hour (¢/kWh), oil and propane in cents per litre (¢/L), natural gas is priced in cents per cubic metre (¢/m<sup>3</sup>) or in dollars per megajoule (\$/MJ), or dollars per gigajoule (\$/GJ), and wood in dollars per cord. You must consider the heat content of the various energy sources to determine the most cost-effective energy source for your area. Check with your local utility or fuel supplier for the unit prices of energy sources in your area. **Table 1** on page 35 gives the energy content for the various energy sources in the units in which they are commonly sold.
3. *Equipment efficiency.* The efficiency with which the appliance converts the energy source to useful heat in the home is also an important factor in the heating cost equation. For example, if a furnace has an AFUE (see page 36) of 80 per cent, then 80 per cent of the heat value in the fuel is available. The other 20 per cent is lost, mostly up the chimney. Thus, additional fuel must be consumed to make up for these losses. Improving the efficiency of the heating equipment reduces energy use and cost.

The combination of heating load, fuel choice, and equipment efficiency determines the annual cost of heating. A detailed description of how you can calculate heating costs for various energy sources and technologies is given in Chapter 3, page 34 along with typical seasonal efficiencies (AFUE) for a range of technologies.

In the end, a homeowner thinking about a new heating system must balance the capital cost against the operating cost and make the best financial decision, taking into consideration how energy prices might change in the future. Since annual operating costs (and the differences in operating costs with different technologies) are very significant compared to capital costs, an investment in high-efficiency equipment is often very wise.

## **ENVIRONMENT**

The effects of energy production and consumption play an important role in many of today's key environmental problems. Exploration and extraction for fossil fuels in fragile ecosystems, fuel spills and leaks during transportation, urban smog, acid rain problems, and global warming—all can have an adverse affect on our environment. Each form of energy has a different impact at various points in the energy cycle. No form of energy is completely harmless, although the environmental impacts of some sources of supply, such as passive solar energy, are relatively insignificant.

Heating your home can affect the environment in different ways, from gases leaving the chimney, to emissions at a coal-fired generating station, to flooding vast stretches of land during the construction of a remote hydroelectric site. The overall environmental impact is determined by the amount and type of fuel your heating system uses.

Selecting the cleanest energy source is within your power—but this is often a complex assessment that may vary between regions in Canada. The combustion of natural gas, propane, or fuel oil in your furnace releases various pollutants into the local environment.

While it is easy to blame pollution on combustion products from your fuel-fired heating system, it becomes more complex when electricity is involved. Electricity is clean at the point of use, but it has environmental impacts at the point of generation. In the provinces of Alberta, Saskatchewan, New Brunswick, Nova Scotia, Prince Edward Island, Newfoundland, and Ontario, coal or heavy oil is burned to meet electricity demands during the winter. In other provinces—Manitoba, British Columbia, and Quebec—where winter peak demand is met by hydroelectric power, the environmental impact at the point of generation is much less obvious. However, in some instances, emissions of methane can be high in major hydro dam projects. Nuclear power has its own set of environmental problems.

In short, there is no easy solution but by buying an efficient system with the most appropriate energy source for your area, you can make a major contribution to environmental health. Other approaches that can help you do your part to reduce energy use and its impact on the environment include improving insulation and airtightness, while ensuring proper ventilation, maintaining your heating system, installing setback thermostats, and improving your heat distribution system.

### **Step 3. Selecting or Improving Your Heat Distribution System**

Most heating systems today are either forced-air systems or hot water (hydronic) systems. These systems consist of a heating unit (furnace or boiler), a distribution system (ducts and registers, or pipes and radiators), and controls (such as thermostats) that regulate the system. Some houses use space heaters and do not have distribution networks.

#### **FORCED-AIR SYSTEMS**

By far the most common type of central heating system used in Canadian homes is a forced-air system, with a furnace as the heat source. Among its advantages is its ability to provide heat very quickly; the fact that it can also be used to filter and humidify household air, and its ability to provide ventilation and central air conditioning. In addition, the furnace

fan can be used year-round to provide continuous air circulation throughout the house, while efficiently balancing the distribution of heat in colder months.

Forced-air systems also have some disadvantages. The air coming from the heating registers, can sometimes feel cool, especially with certain heat pumps, even when it is actually warmer than the room temperature. The effect is much the same as the cooling action of a fan or a summer breeze. In addition, there can be short bursts of very hot air, especially with oversized systems. Some people find these characteristics uncomfortable. The ductwork that distributes the heat may also transmit the noise of the furnace and its circulating fan, and can circulate dust as well as cooking and other odours throughout the house. Consult your heating contractor for further information.

## **HYDRONIC HEATING SYSTEMS**

A hot-water or hydronic heating system uses a boiler to heat water, which is then circulated through the house before returning to the boiler to be reheated.

Contemporary hydronic heating systems typically produce and circulate hot water at approximately 82°C (180°F) in a closed system.

Hot water or steam heating systems once had large boilers and used wrought-iron pipes and massive cast-iron radiators; many of these are still around in older homes. For many years now, installers have been using thinner copper piping, slim baseboard heaters, and smaller, more efficient boilers. Recently, CSA-approved plastic piping has become available as an alternative to copper piping for space heating and service hot-water distribution.

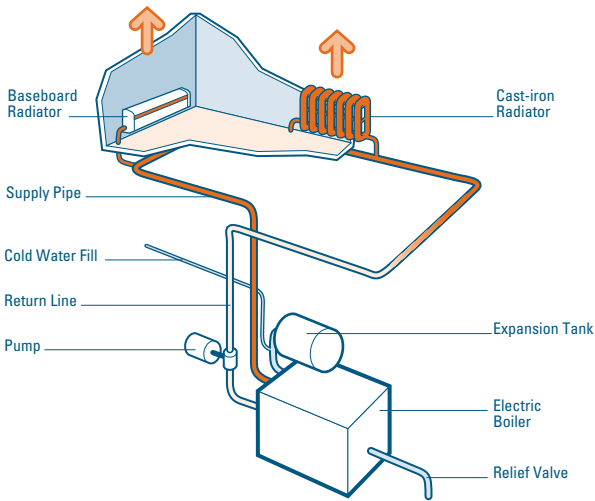

**Figure 1:** Hydronic heating system

## OTHER TYPES OF SYSTEMS

Apart from the more popular systems noted above, others that can be used independently or in combination with conventional systems are also available. These include **room space heaters**, **radiant space heaters**, and **built-in radiant systems**.

**Room space heaters** provide heat directly to the rooms in which they are located and do not have a central heat distribution system. Obvious examples are wood stoves, vented oil-fired space heaters, and electric or gas-fired baseboard heaters.

Some space heaters can also be very effective radiant heat sources, warming solid bodies (like people) in their line-of-sight without necessarily having to heat up all the ambient air. Good examples are the new direct-vent gas fireplaces, advanced combustion wood fireplaces and portable electric infrared radiant heaters. If properly located in a major living space, a **radiant space heater** can actually act as an effective auxiliary heating system, lowering the overall heat requirements of the house and the heating bill, while making the occupants feel more comfortable.



**Built-in radiant systems** are generally of two types: hot water pipes in floors or electrical cables in floors which may also be installed in ceilings. The radiant floor type, becoming increasingly popular, consists of narrow hot water pipes embedded in the floor. Hot water at around 40°C (104°F) is pumped slowly through the pipes and radiates heat into the house. Thick carpets can reduce effectiveness significantly by acting as insulation. Such a system may be more costly to install and does not appear to offer much in energy savings. However, some radiant floor installations may offer comfort benefits, resulting in lower thermostat settings and reduced heating bills.

Your choice of a heat distribution system may be limited if you have a warm air or hydronic system already in place. If you have electric baseboards and are faced with high heating bills, you may wish to change to another type of system, even though it can be an expensive undertaking. Your final choice will probably be based on your answers to one or more of the following questions:

- How much will the system cost compared to others?
- Will this type of system suit my lifestyle? Will I be comfortable with it? Do I want central ventilation, air conditioning, or air circulation?
- Is there a contractor available to install the system?
- Is the system compatible with my energy choice?

## **HEATING WITH ELECTRICITY — WHAT ARE YOUR OPTIONS?**

Electricity can be used as the sole heating source or in combination with other sources in a home heating system.

The five basic types of electric heating systems available in Canada are as follows:

- forced-air systems (which can be electric resistance heating, a heat pump or a combination of the two)
- hydronic or hot water systems
- room heaters
- radiant systems
- combination systems with plenum heaters in the hot air plenum.

An increasing number of homeowners with electric base-board heating are switching to other energy sources, such as natural gas, oil or heat pumps, because of the high cost of electric heating. While a major constraint is the lack of a distribution system, many homeowners find that air ducts for a central forced-air system, or pipes and radiators for a hydronic system, can be installed at a cost that still makes the whole conversion financially attractive. Fuel-fired space heaters, wood stoves, and advanced, energy-efficient wood- or gas-fired fireplaces can also be effective.

#### **Step 4. Selecting Your Heating Equipment**

Once you have selected your energy source options and your heat distribution system, you can begin to consider your alternatives regarding heating equipment and efficiency levels. At some point in your evaluation, you will have to consider whether to upgrade your existing heating equipment or to replace it entirely. A number of things can be done to improve the efficiency of an existing heating system. You also have the choice of several different replacement models with various efficiency ratings and prices.

Here are some details to consider when choosing your equipment:

##### *Equipment Efficiency and Suitability*

Refer to Chapters 2 and 4 of this booklet for a more detailed discussion of your options for electric heating.

##### *Purchase, Installation, Operation and Maintenance Costs*

Generally, the efficient heating systems have a higher capital cost. This must be kept in mind when considering any changes or new equipment purchases. In short, you will want to make sure that the reduction in energy consumption and enhanced comfort will reimburse your improvement costs within a reasonable time. More often than not, they will.

##### *Servicing and Guarantees*

It is also important to know the type and frequency of servicing your system requires, the price of parts, cost of servicing, and details of guarantees and warranties, such as the period covered, and if parts and labour are included. Before you

finally decide on a particular model or type of furnace, ask the seller to give you the names of a few people who have bought this equipment, and ask for their opinions.

### *Energy-Efficiency Standards*

The federal government has implemented energy-efficiency standards for some heating equipment and other energy-consuming appliances and products. Various provincial governments have also introduced energy-efficiency standards, and other provinces have stated their intention to follow suit. Generally, these standards establish the minimum acceptable energy efficiency for specific types of heating equipment. Once the standards are in place, low-efficiency models that do not meet the standard are no longer allowed on the market in that particular jurisdiction.

### *Availability*

Depending on where you live, you may have some difficulty finding the type of furnace, heat pump or boiler you want. This is because the manufacturers' distribution networks may not be developed for all models in all parts of Canada or because certain models have been discontinued due to government minimum-efficiency standards.

## **2. BASIC EQUIPMENT FOR ELECTRIC HEATING SYSTEMS**

In this chapter, the equipment making up different types of electric heating systems will be described.

### **Equipment for Forced-Air Systems**

#### **DESIGN AND OPERATION**

When an electric furnace delivers heated air blown by a fan through a network of ducts, it is called a forced-air system. Because the fan is literally forcing air into each room in the house, this type of system does not depend on natural convection to distribute heated air evenly throughout your house.

Forced-air systems come in a wide range of capacities—generally from 10 kW to 50 kW. The heating elements, circulation fan, air filter, and control devices are contained in a compact cabinet. The equipment would be quite different if a heat pump was being used (see page 30).

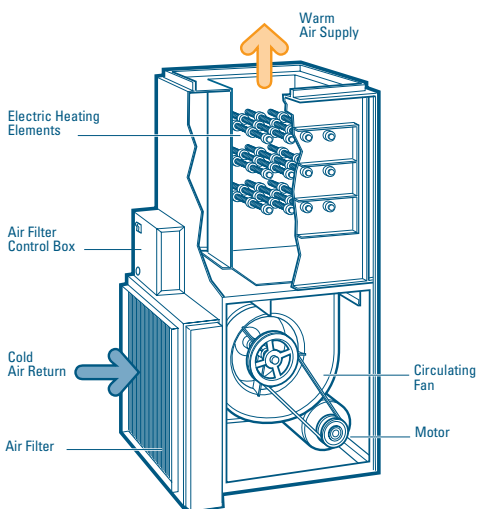

**Figure 2:** Central furnace for an electric forced-air system  
If electricity is your only energy source, unused chimney flues can be closed off, insulated, and sealed. Closing off the chimney flues can have an effect on drafts and humidity levels in the house, and will reduce heat loss.

To accommodate different types of houses, there are three main furnace designs for use with forced-air systems. The designs are named according to the way air travels through the system.

- **Upflow** furnaces are recommended for basement floor locations.
- **Horizontal flow** furnaces are particularly suited for crawl space installations.
- **Downflow** furnaces are recommended for installations in mobile homes or on the main floor of houses on concrete slabs.

If you replace your forced-air furnace with a new electrical furnace, you can usually use the existing ductwork with very few modifications.

Electric plenum heaters can be added to forced-air systems to boost capacity or create dual-energy systems. The plenum heater, consisting of one or more heating coils, is placed in the hot air plenum of the heating system (the plenum is that part of the ductwork immediately downstream from the furnace). The furnace circulating fan blows air through these coils on the way to the warm air registers.

**NOTE:** *Any additions or alterations to an existing furnace involving installation of an electric plenum heater must be done by qualified contractors. The furnace must then be inspected, usually by the local electric utility representative.*

## **MAXIMIZING EFFECTIVENESS IN FORCED-AIR HEATING SYSTEMS**

There are several ways to improve the performance of an existing forced-air heating system.

### *Adjusting the Furnace Fan*

Heat output from a forced-air system can often be increased by adjusting the controls that turn the fan on and off automatically. The fan controls are usually located in a metal box, often mounted on the front of the furnace, near the top. Inside the box is a temperature dial with three pointers (**Figure 3**). (To remove the cover, you must either squeeze it or remove some metal screws.) The lowest setting is the fan OFF pointer; the next one is the fan ON setting. The third and highest pointer is the safety limit control that shuts off the electric elements if the furnace gets too hot. The safety limit is normally set at the factory. **Do not adjust this safety limit setting.**

**Figure 3:** Circulating fan control

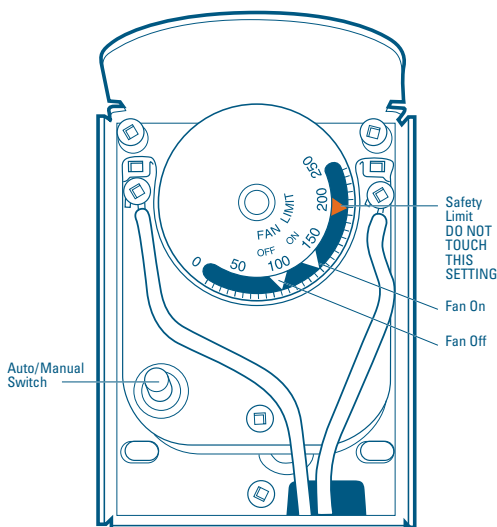

The ON-OFF fan control pointers have usually been set for an ON temperature of 66°C (150°F) and an OFF temperature of 49°C (120°F). To increase the amount of heat taken from the furnace, most heating experts now recommend changing these to an ON temperature of 49°C (120°F) and an OFF temperature of 32°C (90°F). These changes will cause the fan to turn ON sooner after the electric elements come on and will have the fan stay on longer after they turn off. This allows the circulating air to extract more heat from the furnace.

The fan control dial is spring-mounted, so it must be held firmly with one hand, while you adjust the pointer with the other. Make sure the “Auto/manual” switch is set to “Auto” after replacing the cover of the metal box. **If you feel uncomfortable or unsure of about modifying the settings, ask your furnace serviceworker to make the setting changes for you during his next service call.**

These modified temperature settings may result in slightly lower air temperatures coming from the room registers at the beginning and at the end of the furnace cycle. If the cooler air at either end of the cycle makes you feel uncomfortable, try raising either the fan ON setting to 54°C (130°F) or the fan OFF setting to 38°C (100°F), or try both.

A two-speed fan will allow you to get more heat out of the furnace, while providing for continuous air circulation and more even temperatures throughout the house when the furnace is off. However, it will be at the cost of an increased electricity bill.

Some of the new high-efficiency furnaces use a more efficient, variable-speed direct-drive commutating motor to run the circulating fan. The speed of the fan varies depending on the heat demand. For extended or continuous fan operation, such a unit can save a significant amount on your electricity bill, while making the delivery of heat more even and comfortable.

### *Getting the Heat Where You Want It*

Uneven heat distribution is sometimes a problem, which often results in the inability to heat some rooms in the house, such as upstairs bedrooms. This can be due to leakage of warm air out through joints in the heating ducts, or heat loss from ductwork passing through the basement or, even worse, through unheated areas such as a crawl space, an attic, or a garage.

**Seal all joints in the ductwork with a special water-based duct mastic (sealant) to eliminate warm air leaks.** Look in the Yellow Pages™ under “Furnaces—Heating” or “Furnaces—Supplies and Parts”. (High-temperature duct tape may work, although it tends to degrade or permit air leakage over time).

When the circulating fan is running, heat loss can significantly increase if leaky ducts are located in an exterior wall, an attic or a crawl space and allow the heated air to escape. This is one more good reason to ensure all the ducts are well sealed.

Ducts passing through unheated areas such as a crawl space or an attic should be sealed, then wrapped with batt or **duct insulation**. The same may be done for long duct runs in the basement. As a minimum, it is recommended that the warm air plenum and at least the first three metres (ten feet) of warm air ducting be insulated. Better still, insulate all the warm air ducts you can access. Use batts of insulation with

foil backing or wrap them in insulation between the joists, then add a covering. If your basement is presently heated by the heat loss from the ducts, it may be necessary to have additional registers installed in the basement after you insulate them. This will help to ensure that the heat will go only where you want it, without being lost along the way.

Rooms on upper floors or those far from the furnace are sometimes difficult to heat, because of the heat losses mentioned in the above text, as well as because of friction inside the ducts and other resistances to airflow, such as 90° elbows. This can sometimes be corrected by slight modifications to the ductwork, after the ducts have been well sealed and insulated, and by balancing the airflow in the supply ducts (**Figure 4**) to redirect the flow of air from the warmer areas to the cooler rooms.

**Figure 4:** Balancing damper in a supply duct

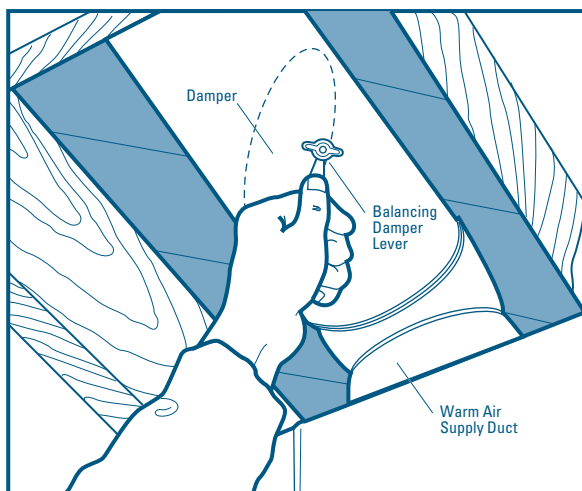

In some forced-air distribution systems, balancing dampers may be located in the secondary warm air ducts, close to where they branch off from the rectangular main heating duct. Often the dampers can be identified by a small lever on the outside of the duct, as shown in **Figure 4**. The position of this lever (or sometimes a slot in the end of the damper shaft) indicates the angle of the unseen damper inside the duct. If there are no such dampers, you will have to use the



ones in the floor registers. Begin by closing the dampers in the ducts that supply heat to the warmest rooms (even if completely closed, they will probably still supply some heat to these rooms). Wait a few days to see what effect this has on the overall heat balance, then make further adjustments if necessary. Such adjustments may slightly reduce the total airflow through the furnace, but this will to some extent be offset by a slight increase in the temperature of the delivered air.

However, you should be careful. It may be more practical to have an experienced service technician make the adjustments. If you make too large a reduction in the airflow, you could cause an undesirable increase in the temperature of the air inside the furnace plenum. It is a good idea to have your furnace serviceperson check this temperature rise.

Most houses have been designed with inadequate cold air returns. The result is that there is not enough airflow through the furnace. Additional cold air returns in the living areas, particularly in the bedrooms, can improve air circulation and heating system efficiency, while improving comfort and air quality in the house.

For stubborn heat distribution problems that cannot be corrected by damper adjustments and other duct modifications, you should have a qualified serviceperson conduct a thorough check and proper balancing of your distribution system.

## **Equipment for Electric Hydronic Systems**

### **DESIGN AND OPERATION**

Electric hot water or hydronic systems deliver heat to a house by means of hot water. The three main components of such a system are:

1. a boiler to heat the water;
2. heating equipment — generally baseboard heaters or radiators — in most rooms, often installed against an outside wall; and
3. a pump to circulate water from the boiler to the radiators and ensure that it flows back through the pipes.

**Figure 5:** Central boiler for an electric hydronic system

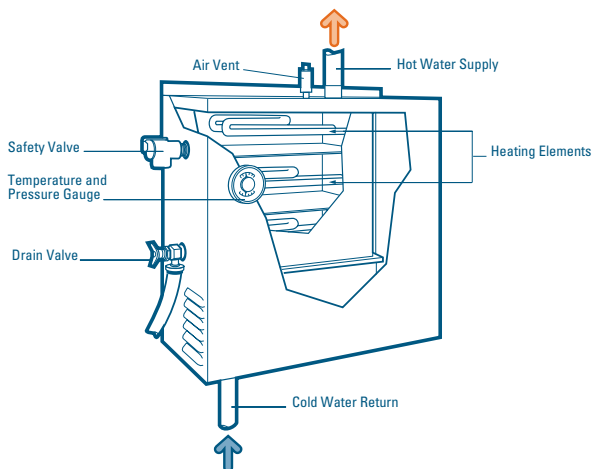

The boiler in an electric hot water heating system is compact. Its heating elements are immersed directly in the water (as in an electric kettle). Where space is limited, the boiler can be installed on a basement wall, in a closet, under a kitchen cabinet—it can even be hung from basement ceiling joists.

If you are replacing a boiler in an existing hydronic system with a new electric boiler, you can probably use the existing heat distribution pipes.

## MAXIMIZING EFFECTIVENESS OF HYDRONIC SYSTEMS

As with forced-air furnaces, there are several ways to improve the performance of hydronic heating systems.

### *Improving Heat Distribution*

Old-fashioned gravity systems that circulate the water by natural convection are much less efficient than systems that use pumps. Slow hot water circulation causes home temperatures to fluctuate noticeably, and it takes a long time to restore temperatures after a night-time setback. Also, a gravity system cannot circulate hot water to radiators or baseboard heaters in basement living areas, where they would be below the level of the boiler. All of these problems can be overcome by adding a circulating pump, and replacing the

open expansion tank in the attic with a sealed and pressurized expansion tank near the boiler. If you have a gravity system, consult your heating and plumbing contractor about the possibility of improving it.

### *Balancing the Heat*

Balancing the heat delivered to different areas of the house is as important with hydronic heating as it is with a forced-air system. Radiators are often fitted with simple manual valves that can be used to control the amount of water flowing through them. Such valves can be used to vary the heat delivered to different rooms in the same way that balancing dampers are used in a forced-air system.

One device that can vary the heat output automatically is a thermostatic valve (**Figure 6**) that can be set to control the temperature in any room. However, this will not work on radiators or baseboard heaters installed on what is called a “series loop” system. In a “series loop”, the water must pass through all the heating units on its way back to the boiler. If there is more than one loop in the system, some balancing of the heat output can be achieved by adjusting the valves that control the water flow through each loop. The same type of baseboard radiators are equipped with built-in air dampers which allow heat output to be regulated to some extent.

**Figure 6:** Thermostatic radiator valve

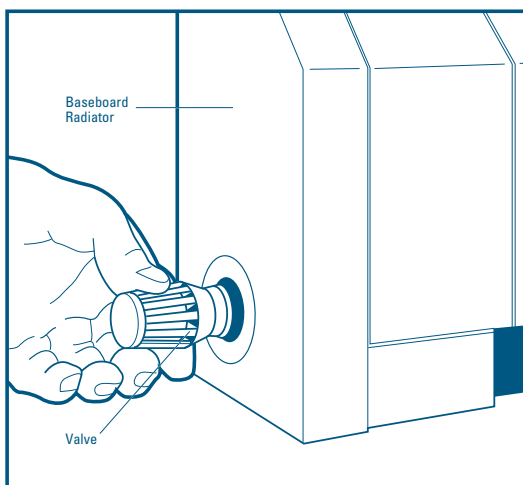

Conventional hydronic systems usually have the boiler temperature set at 82°C (180°F). It is possible to reduce energy consumption in a number of hydronic systems by means of a regulator valve that causes the temperature of the water circulating in the system to vary in relation to the temperature outside. As it becomes warmer outside, the temperature of the water is reduced.

### **Automatic Setback Thermostat**

The easiest way to save heating dollars is to lower the temperature setting of your home, when possible. An automatic setback thermostat will adjust your home's temperature automatically. These thermostats have a mechanical or electronic timer that allows you to preset household temperatures for specific periods of the day and night. As a general rule, you will save two per cent on your heating bill for every 1°C you turn down the thermostat at night.

The thermostat can be programmed to reduce the temperature an hour before you go to bed and to raise it again before you get up in the morning. You could also reduce the temperature during the day when the house is unoccupied, and raise it shortly before you return. For example, you could have the temperature set at 17°C (63°F) when you are sleeping or not at home, and at 20°C (68°F) when you are awake.

Experiment with the unit until you find the most comfortable and economical routine for you and your family.

If you have a hydronic system, you can also reduce energy usage through zone control. With this system, thermostat-controlled valves on each radiator permit the control of individual room temperatures. A heating and plumbing contractor can provide more information about zone control and can install all the required equipment when the heating system is installed. Zone controls are also available for forced-air systems, usually with dampers in main heating ducts controlled by separate thermostats located in various parts of the house.

*NOTE: For all-electric heat pump systems, setback thermostats are generally not recommended.*

### **Improved thermostats**

Greatly improved electronic thermostats are now available on the market. They are very sensitive and help reduce temperature fluctuations to less than 0.5-1C°, whereas fluctuations usually range on an average from 1.5-2 C°. They ensure that the furnace or electric baseboard heater starts up as close as possible to the set temperatures. The energy savings generated by these devices vary according to the model.

One model used with baseboard electric heaters will switch the heater on and off to maintain ambient temperature within +/- 0.5°C of the set point. It could save around 3% on energy use while improving comfort considerably. This model, however, is not recommended for fuel fired furnaces or wherever short cycling is not desirable.

## Electric Room Heaters

Electric room heaters can be installed in each room and individually controlled. The thermostat controls can be located in the units themselves or be mounted on a nearby wall. All room heaters have built-in controls to prevent overheating if airflow is restricted. A wide variety of moderately priced room heaters are available.

The most common type of room heater is the *baseboard heater* (**Figure 7**). These units are installed permanently, preferably under windows, along outside walls in an unobstructed space. They rely on the natural convection of heated air to distribute heat. These units are available in different lengths, suitable to the heating requirements of a room.

**Figure 7:** An electric-resistance baseboard heater

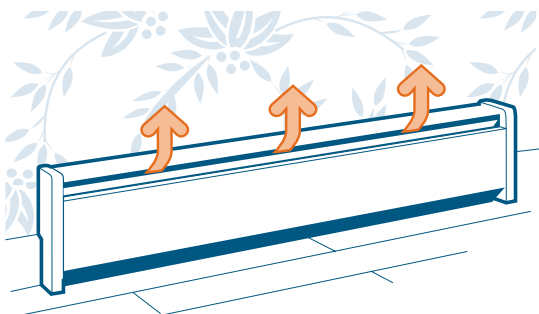

Electric baseboard heaters consume a lot of electricity. Each baseboard heater normally requires its own dedicated electric circuit. The easy installation of this wiring is a factor in evaluating the cost of the system. In newly constructed structures or buildings, baseboard heating usually has the lowest initial cost compared to other systems, but often has very high operating costs.

## Other Types of Electric Heaters

If a baseboard heater installation is difficult, impossible, or expensive other types of electric heaters can also do the job. *Portable heaters* (**Figure 8**), whether convection or fan-assisted types, range from 500- to 1500-watt capacity and come in many models, shapes, colours and sizes. They are small enough to plug into regular house circuits and are useful for auxiliary or temporary heating. Make sure, however, that your house wiring can handle the additional electric load.

Portable units should be considered as supplementary units to the existing heating system. They may not be appropriate for wet locations.

**Figure 8:** A portable electric room heater

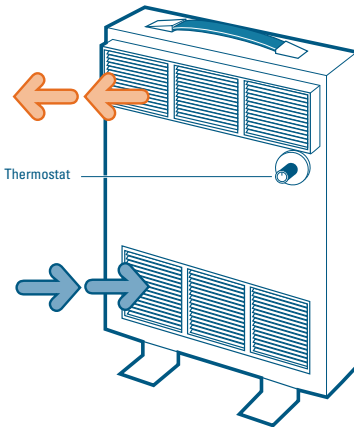

*Wall convection heaters* can be mounted onto a wall or recessed into it (see **Figure 9 below**). They are suitable as primary or auxiliary heat sources for confined areas such as hallways, entrances, landings and bathrooms. Portable convection heaters, of the same type, are available for auxiliary heating. Some units have small fans to distribute heat more quickly. *Floor insert units* (see **Figure 10 on page 28**) are designed for use in front of stairways, floor-level windows or sliding glass doors. These units are installed into the floor.

**Figure 9:** Wall convection heater

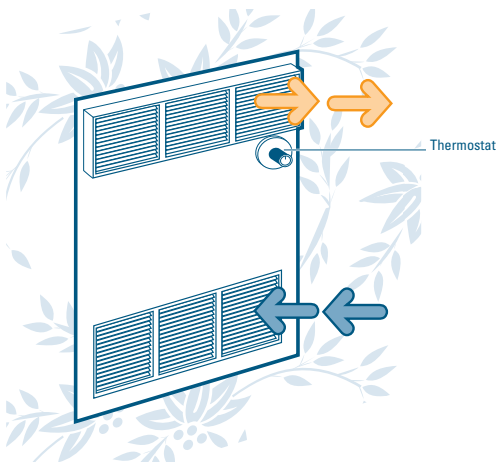

**Figure 10:** Floor insert unit

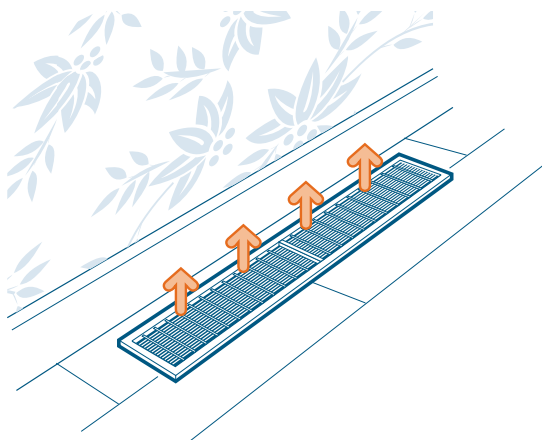

Other types of electric heaters, such as oil-filled rods, quartz heaters and duct heaters are also available. Check with a local distributor, your local electric utility, or a local contractor for more information. Some products are designed as booster heaters for existing forced-air heating systems. The installation of duct heaters requires a qualified contractor.

## “Combination Systems”

### WOOD-ELECTRIC

*Wood-electric combination furnaces* (Figure 11) are common in rural areas. These are wood furnaces that contain built-in heating elements that are only activated if the wood furnace cannot meet the heating requirements of the home. Electric baseboard heaters can also be used to supplement a central wood furnace, a wood-oil combination furnace, or a wood stove.

**Figure 11:** A combination wood-electric furnace

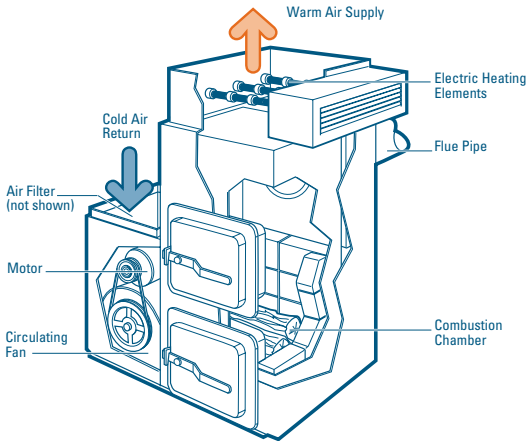

*NOTE:* An electric plenum heater cannot be added to a forced-air wood furnace.

## OIL-ELECTRIC

An oil-electric combination system (see **Figure 12** below) consists of an oil furnace with factory-installed electric heating elements. The electric elements supply a large part of the heating requirements, with the oil burner kicking in only during very cold weather.

**Figure 12:** An oil-electric combination furnace

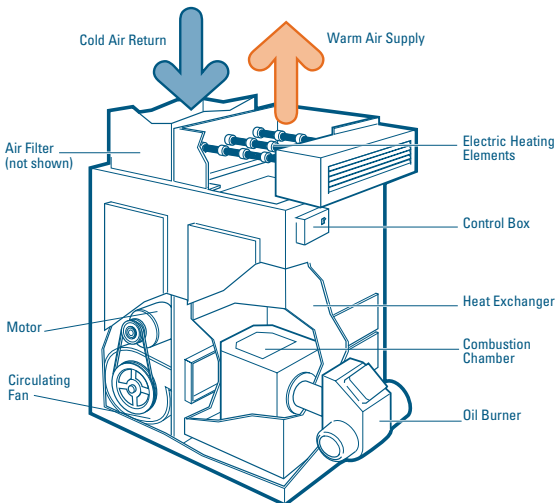



Another option is to add an electric plenum heater to a forced-air oil heating system. In milder weather, the furnace fan and plenum heater are used to heat the house. During colder weather, higher electricity costs turn oil into a lower-cost heating source. Dual energy rates exist in the province of Quebec to encourage such usage. This rate may also apply when heat pumps are used in conjunction with fuel fired furnaces.

## Heat Pumps

Heat pumps produce useful heat by transferring or pumping heat from one place to another. Since it normally takes less energy to transfer heat than to generate it, heat pumps can be very energy efficient.

Although a heat pump is technically similar to a household refrigerator, it can be used for both heating and cooling houses. In the summer, it removes heat from the air inside the house and transfers it outside, much like a conventional air conditioner. In the winter, the heat pump operates in reverse, removing heat from the cold outside air or ground, and transferring it inside the house.

Residential heat pumps are divided into two major groups: *air-source (air-to-air)* and *ground source*. Each type will be briefly described here. For more information, refer to a companion booklet in this series entitled *Heating and Cooling with a Heat Pump* (see page 52).

### AIR-SOURCE HEAT PUMPS

A typical residential *air-source heat pump* (**Figure 13**) resembles a residential central air conditioner. In fact, the only difference between a heat pump and an air conditioner is the heat pump's ability to reverse the flow of refrigerant so that the equipment can provide heating in the winter as well as cooling in the summer. Even cold air contains heat. Because heat is absent only at absolute zero ( $-273^{\circ}\text{C}$ ), heat pumps can operate even during the coldest Canadian winters.

However, both efficiency and capacity decrease with significantly lower outside temperatures.

## Mini-split heat pumps

“Mini-split” heat pumps, which have a small air-handler mounted on an inside wall to supply heating and cooling to a single room, have recently become available. These systems work equally well as a window air conditioner, but are much quieter and have higher efficiencies. However, they can be expensive.

**Figure 13:** An air-source heat pump during the heating cycle

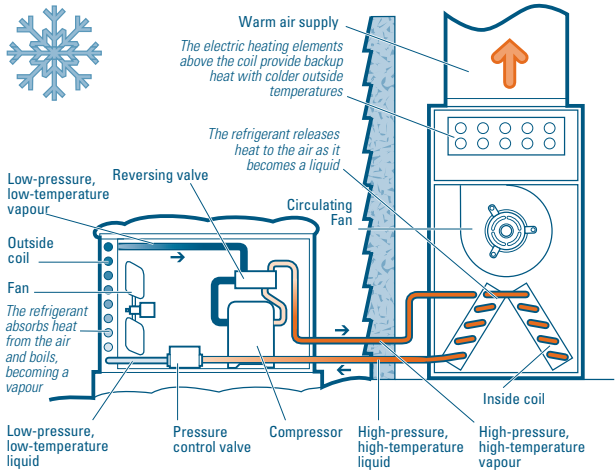

Because the output of air-source heat pumps declines with decreasing outdoor temperature, the house’s heat load increases. Thus, air-source heat pumps are normally equipped with supplementary or auxiliary heating equipment, such as electric plenum heaters, or oil- or gas-fired furnaces to meet the heat load of the house in colder weather.

The actual performance of a heat pump is indicated by The heating seasonal performance factor (HSPF) which is the quotient of amount of heat delivered, divided by the amount of electricity consumed by the heat pump over its period of use during the heating season. The higher the HSPF, the more efficient the heat pump.

## **GROUND-SOURCE HEAT PUMPS (EARTH-ENERGY SYSTEMS)**

Ground-source heat pumps are different from air-source heat pumps. Heat is extracted from the ground or underground water instead of air. For this reason, ground-source heat pumps have come to be known as “earth-energy systems” (EESs).

Since the temperature of the ground or ground water is much higher than the ambient air in winter and is fairly constant, the output of GSHP does not fall with colder outside temperatures. Thus, in colder climates, EESs are effective.

### **The New Technologies**

In recent years, the heating industry has concentrated more on oil and natural gas heating systems than electric ones. Nevertheless, in addition to ground-source heat pumps there have been some real breakthroughs in electric heating.

## **ELECTRIC THERMAL STORAGE**

Electric Thermal Storage (ETS) heating was developed in Europe in the 1940s, and was introduced to the United States market in the 1980s. This type of space-heating system is capable of providing all of a home’s heating requirements by storing heat produced during the night, when utilities generally offer lower off-peak rates. Most of the ETS systems now available can provide 24 hours of on-peak heat from as little as eight hours of off-peak charge.

The ETS central furnace consists of a storage medium (usually called the core) and controls, which detect when it is necessary to accumulate a charge during the off-peak period. Elements within the storage core heat ceramic bricks, crushed rock, or water to a predetermined temperature level to provide the heating requirements for the entire on-peak period. Room storage units are smaller versions of central ETS furnaces. They come in a variety of sizes, from 2.0 to 7.2 kilowatts and supply the heating for individual rooms. Larger rooms in the home may sometimes require more than one storage heater.

These systems can offer savings of up to 30 per cent on heating costs, if there are significantly lower off-peak (night) electricity rates.

### **Condensation Problems**

Electrically heated homes may experience problems of high indoor humidity because of a lack of a chimney, and therefore, have lower rates of air exchange.

Heavy condensation on the inside of windows, stains or mould on walls or ceilings are indicators of too much moisture. If this problem is not remedied, serious structural damage can occur. Fortunately, indoor condensation problems can be solved. Because most of the indoor humidity comes from regular household activities, such as showering and cooking, your first step should be to reduce the amount of moisture from these sources. For example, ensure that your dryer vents to the outside, that you cover your pots with lids when cooking, and that you take shorter showers. You should consider installing exhaust fans in the bathroom and kitchen to vent moisture directly outside. Check the setting of the humidifier of your forced-air furnace as well, if you have one. In more air-tight houses, humidifiers are not necessary. As a last resort, you could talk to a contractor about installing a Heat Recovery Ventilator (HRV) that will increase the house's ventilation and decrease its humidity without wasting energy.

### 3. COMPARING ANNUAL HEATING COSTS

The combination of heating load, energy source and heating equipment efficiency determines the annual cost of heating.

#### Calculating Heating Costs with Different Energy Sources

You may be interested in calculating the costs of heating with electricity and even comparing this amount to the costs of heating with other energy sources such as natural gas, propane, oil or wood. In this case, you can use the following procedure. First you need to find out the cost of the energy sources you wish to compare and the characteristics of the heating systems that you are considering.

#### Step 1: Determine the Price of Energy Sources in Your Area

Call your local electric utility, or gas or fuel suppliers to find out the cost of energy sources in your area. This should be the total cost of fuel delivered to your home, including any basic costs for which the supplier might bill you, as well as rental charges, as for, say, propane tanks. Be sure to get the prices for the energy sources in the same units used in **Table 1**. Write the costs in the spaces provided. If your natural gas price is given in gigajoules (GJ), you can convert it to cubic metres (m<sup>3</sup>) by multiplying the price per gigajoule by 0.0375. For example,  $\$5.17/\text{GJ} \times 0.0375 = \$0.19/\text{m}^3$ .

**TABLE 1**  
**Energy Content and Local Price of**  
**Various Energy Sources**

Energy Source	Energy Content		Local Unit Price
	Metric	Imperial	
Electricity	3.6 MJ/kWh	3 413 Btu/kWh	\$0.____/kWh
Oil	38.2 MJ/litre	140 000 Btu/gal (US)	\$0.____/litre
Natural Gas	37.5 MJ/m <sup>3</sup>	1 007 Btu/ft <sup>3</sup>	\$0.____/m <sup>3</sup>
Propane	25.3 MJ/litre	92 700 Btu/gal (US)	\$0.____/litre
Hardwood*	30 600 MJ/cord	28 000 000 Btu/cord	\$ ____/cord
Softwood*	18 700 MJ/cord	17 000 000 Btu/cord	\$ ____/cord
Wood Pellets	19 800 MJ/tonne	20 000 000 Btu/tonne	\$ ____/tonne

*Conversion: 1 000 MJ = 1 gigajoule (GJ)*

*\* The figures provided for wood are for a "full" cord, measuring 1.2 m x 1.2 m x 2.4 m (4 ft. x 4 ft. x 8 ft.).*

## **Step 2: Select the Type(s) of Heating Appliance(s)**

Choose the type of equipment you want to compare from the list of appliance types in **Table 2** on page 36. Note the efficiency figures in the column titled "Seasonal Efficiency". By using these figures, you can calculate the savings you can achieve by upgrading your present system to a newer, more energy-efficient model, or by choosing a more efficient appliance that uses another energy source.

**TABLE 2**  
**Heating System Efficiencies**  
**and Energy Savings**

Energy Source	Technology	Seasonal Efficiency (AFUE) %	Energy Savings % of Base**
Electricity	Electric baseboards	100	
	Electric furnace or boiler	100	
	Air-source heat pump	*	
	Earth-energy system (ground-source heat pump)	*	
Oil	Cast-iron head burner (old furnace)	60	Base
	Flame-retention head replacement burner	70-80	14-23
	High-static replacement burner	74-82	19-27
	New standard model	78-86	23-30
	Mid-efficiency model	83-89	28-33
	Integrated space/tap water system (mid-efficiency)	83-89	28-33 space 40-44 water
Natural Gas	Conventional	60	Base
	Vent damper with non-continuous pilot light	62-67	3-10
	Mid-efficiency model	78-84	23-28
	High-efficiency condensing furnace	89-97	33-38
	Integrated space/tap water system (condensing)	89-96	33-38 space 44-48 water
Propane	Conventional model	62	Base
	Vent damper with non-continuous pilot light	64-69	3-10
	Mid-efficiency model	79-85	21-27
	Condensing model	87-94	29-34
Wood	Central furnace	45-55	
	Conventional stove (properly located)	55-70	
	"High-tech" stove (properly located)	70-80	
	Advanced combustion fireplace	50-70	
	Pellet stove	55-80	

\* Consult specialists.

\*\* Base represents the energy consumed by a standard furnace.

### Step 3: Select your House Type and Heating Load

From the list of cities and housing types in **Table 3**, select the combination that corresponds best to your area and house type. The heating load figures are expressed in metric units called gigajoules (GJ).

**TABLE 3**  
**Typical Annual Heating Loads in Gigajoules (GJ) for Various Housing Types in Canadian Cities**

City	Old Detached	New Detached	New Semi-Detached	Town-house
Victoria	85	60	45	30
Prince George	150	110	80	60
Calgary	120	90	65	50
Edmonton	130	95	70	55
Fort McMurray/ Prince Albert	140	105	80	60
Regina/ Saskatoon/ Winnipeg	130	90	70	50
Whitehorse	155	115	85	60
Yellowknife	195	145	110	80
Thunder Bay	130	95	70	55
Sudbury	120	90	65	50
Ottawa	110	75	55	40
Toronto	95	65	45	35
Windsor	80	55	40	30
Montréal	110	80	60	45
Québec City	115	85	65	50
Chicoutimi	125	90	70	55
Saint John	105	75	60	45
Edmundston	120	90	65	50
Charlottetown	110	80	60	45
Halifax	100	75	55	40
St. John's	120	85	60	45

Note: **“New”** means houses built after 1990, and **“old”** means houses built before 1990. Due to construction practices, and weatherizing and re-insulating (which can be different from house to house), these figures are only meant to be used as general guidelines; they should not substitute for an accurate heating requirement determination, as discussed in Chapter 5, page 41.

Assumptions:

Old detached - approximately 186 m<sup>2</sup> (2000 ft.<sup>2</sup>).

New detached - approximately 186 m<sup>2</sup> (2000 ft.<sup>2</sup>).

New semi-detached - approximately 139 m<sup>2</sup> (1500 ft.<sup>2</sup>).

Townhouse - inside unit, approximately 93 m<sup>2</sup> (1000 ft.<sup>2</sup>).



## Step 4: Use the formula

The annual heating cost is calculated as follows:

$$\frac{\text{Energy Cost/Unit}}{\text{Energy Content}} \times \frac{\text{Heating Load}}{\text{Seasonal Efficiency}} \times 100\,000 = \text{Heating Cost (\$)}$$

- Enter the cost per unit of energy and divide it by the energy content of the energy source; both numbers come from **Table 1** on page 35.
- Select the heating load for your type of housing and location from **Table 3** on page 37; divide it by the seasonal efficiency of the proposed heating system from **Table 2** on page 36.
- Multiply the results of these two calculations, then multiply that result by 100 000.

The result should give you an *approximate* heating cost for your house. If you know your actual heating costs, as well as the type of heating system you have, you can modify the heating load originally taken from **Table 3** to reflect real load of your house.

**Sample Calculation:** You have a new detached home in Toronto and you would like to know what it would cost you annually to heat your dwelling with an electric forced-air system with a seasonal efficiency of 100 per cent. Using the above equation, let us specify that electricity costs \$0.0826/kWh, the heating load is 80 (**Table 3**) and the energy content is 3.6 (**Table 1**).

$$\begin{array}{l} \text{Annual cost of heating} \\ \text{with electricity:} \end{array} \quad \frac{\$0.0826}{3.6} \times \frac{80}{100} \times 100\,000 = \$1835.55$$

If you would like to compare this heating cost to those of other types of heating systems or energy sources, replace the numbers in the formula with the appropriate ones for your comparison using **Tables 1** and **2**. If you have access to the internet, visit <http://energiguide.nrcan.gc.ca> and check for the Heating Cost Calculator under Heating and Cooling Equipment.

## 4. ACCOMMODATING THE ELECTRICAL LOAD

If you are planning to heat with electricity, it may be necessary to upgrade or adjust your home's electric service in order to cope with the additional load. Two basic approaches are described in this chapter.

### Electrical Service Panels

Usually, a house that is not heated by electricity has a 60A or 100A electrical service output. To install an electric heating system, you may perhaps need to upgrade your home's electric service to 200A or more.

To do this, you should replace:

- the electrical service panel (fuse box or breaker panel)
- the three heavy wires that supply electricity to your home and their housing
- the meter base and receptacle

**Figure 14:** Typical electric service installation

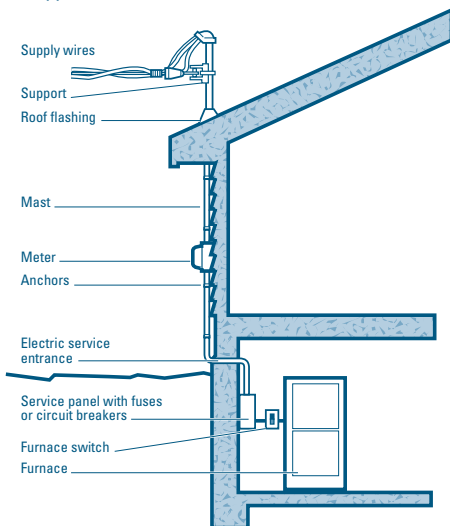

If you are building a new house, consider installing a 200A service for whatever type of heating system you choose. This could avoid costly service upgrading in the future. In general, a representative from your electric utility can evaluate

your consumption of electricity and future needs, and take the final decision regarding your home's required electric service.

Your local electrical utility representative should be consulted before any work begins. Either you or your electrical contractor must obtain a permit from the appropriate authority before any alteration to wiring is undertaken. Some utilities also provide precise information on the cost and installation of a new electric system. The installation must be inspected upon completion.

## **Load Management Devices**

Equipment is now available to manage the extra load placed on a standard (100A) electric service when an electric heating system is added to a household. These load management devices are compatible with any electric heating system, but are used mostly when plenum heaters are added to an oil furnace. A sensor on the wires supplying electricity to the house monitor the amount of electricity used.

If the amount of electricity used in the house is heavy—say when the water heater, the stove and dryer are all in operation at the same time—the device restricts the amount of current allowed to reach the heating elements of the heating system. This prevents an overloaded demand on the house's electricity supply. In oil furnaces using plenum heaters, the load monitor compensates for an increased household demand by temporarily switching off one or more of the plenum heater's elements. Then, as appliances are turned off, the sensor responds by allowing more electricity to flow to the heating system (or by switching the plenum heater's elements back on) up to the full capacity allowed. Except for water heaters and dryers, nearly all the electricity used by household appliances ends up as heat—which compensates somewhat for the slightly lower output by the heating system.

Load monitors may eliminate the need for upgrading to a 200A service. In some provinces, however, electrical utilities may find these devices unacceptable. Check with your electrical utility if you are considering using this kind of equipment.

## 5. THE MECHANICS OF BUYING, INSTALLING AND MAINTAINING A SYSTEM

### Buying Electrical Space Heating Equipment

You cannot shop for a heating system the way you shop for a camera or a pair of shoes. There are no furnace stores where the different makes and models can be examined, compared and priced. To get first-hand information on the different makes and models available, you will have to contact a number of heating firms. Ask them for the manufacturers' illustrated sales literature on the equipment they sell and install. You should also contact your local electrical utility or contractor for assistance and information. Your local utility can provide information on the cost of purchasing or renting, installing your system, and the estimated seasonal heating costs associated with the type of equipment you plan to use.

If you have opted for a particular type of equipment, check the literature carefully, to see if it describes all the features you are looking for.

A heating contractor cannot determine what size of heating system you need just by walking through your house. The "size" of heating system means the heat output from it after it is running in steady-state operation. If you are replacing an existing heating system, the output of that system will only give a rough idea of the maximum size you should consider. The contractor will have to calculate the heating requirement of your house very carefully, using either the fuel consumption of your present heating system over a known winter period, after other usage is factored out, such as for the water heater and kitchen range or by making a thorough measurement and examination of your house to determine size, insulation levels, and degree of tightness of the house envelope. If the contractor does not show any interest in any of the above facts, then his calculation of the correct size for your new heating system is simply a "guesstimate".

To make sure proper sizing is determined, the quotation and contract should include a statement like the following: "The heating equipment size will be determined by a heat loss calculation using the formulas published by the electrical

utility, the Canadian Gas Association (CGA), the Heating, Refrigerating and Air Conditioning Institute of Canada (HRAI), the Canadian Standards Association (CSA), Natural Resources Canada (NRCan), or other recognized organizations. A copy of these calculations will be given to the homeowner.”

It is important to hire a contractor who will install your equipment properly to ensure that it will operate efficiently. Check with your local electrical utility, or provincial regulatory office to find out how to get in touch with a fully qualified, registered or licensed contractor. If your neighbours have had similar work done recently, ask them how satisfied they were with their contractor. If you are buying a relatively new type of furnace design, try to get the name of other homeowners who have had such equipment installed to find out about the appliance’s performance and the workmanship of the installer.

Before you decide what to buy, obtain firm, written bids from several companies on: a) the cost of upgrading your existing equipment and b) the cost of buying and installing a complete new unit, along with any other fittings and adjustments required, including changes to any ductwork or piping and a final balancing of the heat supply to the house. With these figures and a reasonable estimate of the probable annual savings in heating costs determined from Table 2 on page 36, you will be able to determine how long it will take to recover the cost. This is not the only factor to be considered, of course, but it is certainly one of the most important.

Remember that a building permit may be required for this type of work, and the contract should state whether the installer or the homeowner is responsible for obtaining it.

### **CHECKLIST FOR HAVING AN ELECTRIC HEATING SYSTEM INSTALLED**

**You should get several estimates on the work to be done.** When you are comparing these estimates, cost will be an important factor, but there are other considerations involved. Some contractors may be better at explaining what has to be done, some may use higher quality components, and some may schedule the work to your convenience.

Estimates should include the following items:

- The total cost for **all** necessary work.
- An itemized list of **all** material and labour costs included in the bid: alteration or improvement of existing heat distribution ducts; installation of appliance; alteration or replacement of the main service panel and service entrance; alterations to service wires above or below grade to the transformer pole; transformer pole replacement (sometimes the responsibility of the customer in rural areas); installation of water heater (where applicable); and installation of additional equipment such as humidifiers, air cleaners or air conditioners.
- A statement describing how much existing equipment will be used in the new system.
- A rough diagram showing the layout of any new wiring and the location of heating equipment.
- A statement that clearly defines who is responsible for:
  - all necessary permits and payment of related fees;
  - on-site inspections by the utility;
  - scheduling of all other required work by the electrical utility, such as alterations to the transformer or related outside equipment;
  - removal of any existing equipment that will not be used with the new system;
  - all related costs, such as subcontracts with tradespeople;
- A clear estimate of when the work will be completed.
- A warranty for materials and labour.
- A schedule and method of payment.
- A statement that indicates when electric service will be interrupted and for how long.

Ask contractors for the names of homeowners for whom they have done similar work. The Better Business Bureau will know if the contractor is a member and whether any recent complaints have been filed. Your Chamber of Commerce or Board of Trade may also be able to help.

Consider additional upgrading or improvements to house wiring while this work is being done. The provision of split receptacles to kitchen counter areas, an electric stove receptacle, outside lighting, and draftproofing of receptacles in

outside walls may be possible and relatively economical, while the work on the heating system is being completed.

In most provinces, if wiring has been upgraded, a service panel replaced, heating equipment added or load management devices installed, the work must be inspected by the utility, municipality, or province. The contractor should have these inspections done before the circuits are energized or wiring is hidden behind walls.

Do not hesitate to ask the contractor for a clear explanation of any aspect of the work before, during, or after the installation of your heating system.

## **Maintenance**

In general, electric resistance heating systems require relatively little maintenance and they tend to last for a long time without requiring replacement.

Maintenance by contractors is usually limited to the replacement of broken electric heating elements in central electric furnaces or baseboard heaters. Owners can improve the performance of their heating systems by vacuuming the elements on any baseboard heaters and by replacing filters in electric forced-air furnaces.

## **HOMEOWNER MAINTENANCE OF FORCED-AIR SYSTEMS**

### *Cleaning or replacing the air filter*

**IMPORTANT!** Before opening the access panel to the furnace to inspect the filter or circulation fan, turn off the electric power supply to the equipment.

Few homeowners give their furnace air filters the attention they deserve. Filters must be cleaned or replaced once a month. Permanent filters, which are made of aluminum or plastic mesh, can be washed in a washtub. As they are coarser than fiberglass filters, they catch fewer impurities.

If you have installed a domestic electrostatic air filter, you do not need to use an ordinary filter. Do not forget that electrostatic filters must also be cleaned regularly following the manufacturer's instructions.

### *Fan Care*

Besides giving it a superficial vacuuming, there is little you can do to maintain a direct-drive furnace fan with an internal motor. On the other hand, if you have a fan driven by a fan belt, you should place a few drops of oil once or twice a month, during the heating season and also in the summer, if the fan is used for ventilation or cooling, into the small oiling cups over the bearings on each side of the motor. Consult your maintenance manual to determine the type and quantity of oil to use.

You should also check the tension of the fan belt by pressing down firmly with your thumb on the middle of the belt. You should be able to depress it about 20 mm (3/4"), but no more than 25 mm (1"). To adjust the tension, unscrew the bolts that attach the motor and move it forward or backward as required. Make sure that the fan and motor pulleys remain perfectly aligned. The serviceperson is the best person to do this job.

### *Care of the Distribution System*

For better heat distribution, remove any obstructions from the ducts, warm air registers and cold air returns so that the air can circulate freely throughout the system. Use a special water-based duct mastic to seal cracks at duct joints, as described on page 20. At the same time, consider insulating as much of the warm air ducts as are easily accessible.

### *Homeowner Maintenance of Hydronic Systems*

If you have a hydronic system, there are a few things you can do to maintain your system:

- Insulate hot water pipes.
- Once or twice a year, bleed air bubbles out of radiators so that they can be refilled with water.
- Vacuum the radiators.
- Check to see that the level of water in the expansion tank is below flood level.
- Oil the circulating pump (according to the manufacturer's instructions).
- Allow air to flow freely around radiators: make sure that they are not covered by curtains or by ventilated wood panelling, and try to ensure that they are not directly



behind furniture so that the heat generated can get into the rest of the room.

## **BILLING**

Billing for electricity consumption is handled in different ways, with two of the most common ones being equal billing and standard billing.

*Equal billing.* Your electricity bill is paid in regular, equal installments, based on an estimate of your annual total consumption. Periodic adjustments are made to balance your monthly charge against your actual yearly household consumption.

*Standard billing.* The electricity bills are paid on a monthly basis for electricity consumed during that month. Your meter is read periodically and bills are adjusted accordingly.

## 6. ELECTRIC WATER HEATERS

After the space-heating system, domestic water heaters consume the second-largest amount of energy in most Canadian houses. Depending on the type of house and on the number and lifestyles of the occupants, hot water consumption may account for more than 20 per cent of the total annual energy consumption in the home. Many Canadian homes have electric water heaters to supply hot water for household use.

An electric water heater (**Figure 15**) usually consists of a tank, thermostats, two electric resistance elements (which are submerged inside the tank), and inlet and outlet pipes for cold and hot water respectively. Internal thermostats regulate the temperature of the water.

Tanks are typically insulated on the exterior with mineral wool insulation and lined on the inside with a thin epoxy or ceramic glass layer. When hot water is needed, the elements are activated, which then heat the water until it reaches the correct temperature. Essentially, electric hot water heaters are large closed electric kettles. In the past, water temperature was generally maintained at between 60°C (140°F). Today, this temperature has been somewhat lowered to prevent young children from burning themselves.

**Figure 15:** Electric Water Heater

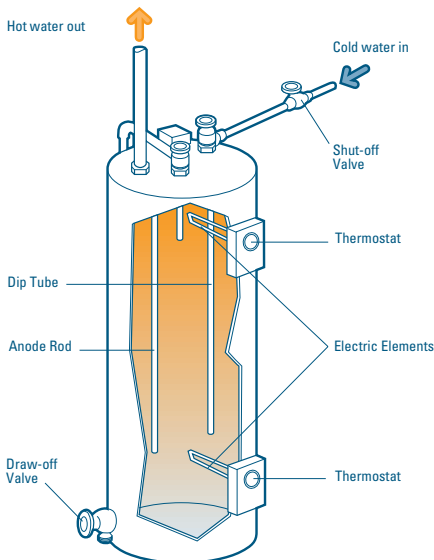

The submerged electric resistance heating elements found in water heaters are very efficient, providing about 99 per cent of the available heat to the surrounding water. Even so, older water heating systems lose considerable heat as a result of standby losses.

## REDUCING STANDBY LOSSES

The term “standby loss” refers to heat lost from the water in a domestic water heater and its distribution system to the surrounding air. It is a function of the temperature difference between the water and the surrounding air, the surface area of the tank, and the amount of insulation encasing the tank.

You should consider the following options in order to reduce standby losses:

- Insulation of the tank with an approved insulating blanket. **It is extremely important not to insulate over any controls and to follow the manufacturer’s instructions.**
- Installation of a heat trap above the water heater. A heat trap is a simple piping arrangement that prevents hot water from rising up in the pipes, thereby minimizing the potential for this loss.
- Insulation of the hot water pipes to reduce heat loss from the pipes themselves. Pipe insulation is available in a variety of materials and thicknesses, with easy application to most hot water pipes. Use insulation with an RSI (insulation value) of at least 0.35 (R-2) over as much of the pipe as you can easily access.
- Placement of the water heater over a layer of rigid thermal insulation to reduce heat loss through the bottom of the tank. This is particularly applicable to electric water heaters or to external storage tanks for integrated space and water-heating systems.

**Before carrying out any of the steps listed above, check with your local installer or electricity utility representative to ensure that you will not compromise the safety or operation of the appliance.**

### *Increased Efficiency Water Heaters*

If you are in the market to buy or rent a new electric water heater, increased tank insulation and heat traps are options that are available to help you save even more energy.

The hot water can also come from a *heat pump electric water heater*. This is often a ground-source heat pump with an additional condenser or heat exchanger. For more information, consult the NRCan booklet entitled *Heating and Cooling with a Heat Pump*.

It should be noted that electric water heaters are regulated by existing efficiency standards which are being evaluated in various regions of Canada.

## **7. Need More Information?**

### **ORDER FREE PUBLICATIONS FROM THE OEE**

The Office of Energy Efficiency (OEE) of Natural Resources Canada offers many publications that will help you understand home heating systems, home energy use and transportation efficiency. These publications explain what you can do to reduce your energy use and maintenance costs while increasing your comfort and helping to protect the environment.

### **ENERGUIDE FOR RENOVATING YOUR HOME**

*Keeping the Heat In* is a guide to all aspects of home insulation and draftproofing. Whether you plan to do it yourself or hire a contractor, this 134-page book can help make it easier. Fact sheets are also available on air-leakage control, improving window energy efficiency and moisture problems. Consider getting the expert unbiased advice of an EnerGuide for Houses evaluation before you renovate. Our telephone operators can connect you with an advisor in your local area.

### **ENERGUIDE FOR HOME HEATING AND COOLING**

If you are interested in a particular energy source, the OEE has booklets on heating with electricity, gas, oil, heat pumps, and wood. Other publications are available on heat recovery ventilators, wood fireplaces, gas fireplaces, air conditioning your home and, comparing home heating systems.

### **ENERGUIDE FOR CHOOSING THE MOST ENERGY-EFFICIENT PRODUCTS**

When shopping for household appliances, office equipment, lighting products, and windows and doors, consult the OEE's series of Consumer's Guides. They'll help you know what to look for when it comes to energy efficiency.

The EnerGuide label, which is affixed to all new major electrical household appliances and room air conditioners, helps you compare the energy ratings of all models sold in Canada. EnerGuide ratings are also listed in the OEE's annual directories of major electrical household appliances and room air conditioners.

## **EVERY NEW HOUSE SHOULD BE THIS GOOD**

R-2000 Homes are the best built, most comfortable homes in Canada, and they use an average of 25 per cent less energy than conventional dwellings. R-2000 homes feature state-of-the-art heating systems, high levels of insulation and whole-house ventilation systems that provide continuous fresh air to all rooms. Subject to quality assurance checks during the construction process, once completed, R-2000 Homes are certified as being energy-efficient.

## **BUYING, DRIVING AND MAINTAINING YOUR CAR**

For information on vehicle fuel consumption, look for the EnerGuide label that appears on every new automobile, van, and light-duty truck for sale in Canada. It helps you compare different vehicles' city and highway fuel consumption ratings and estimated annual fuel costs. You can also check the OEE's *Fuel Consumption Guide*, produced annually, which provides the same information for all vehicles. The OEE's EnerGuide for Vehicles Awards also recognize the vehicles with the lowest fuel consumption in different categories.

Also available is the OEE's *Car Economy Calculator*, a fuel log that helps you calculate your fuel consumption and savings.

The OEE's *AutoSmart Guide* provides detailed fuel efficiency information and offers tips on purchasing, operating, and maintaining personal vehicles.

**To receive any of these free publications,  
please write or call:**

Energy Publications  
Office of Energy Efficiency  
Natural Resources Canada  
c/o S.J.D.S.  
Ottawa ON K1A 1L3

Fax: (819) 779-2833

Toll-free: 1 800 387-2000

In the National Capital Region, call 995-2943.

*Please allow three weeks for delivery.*

**Publications can also be ordered or viewed  
on-line at the OEE's Energy Publications  
Virtual Library:**

**<http://oee.nrcan.gc.ca/infosource>.**

## NOTES



## NOTES

*Leading Canadians to Energy Efficiency at Home, at Work and on the Road*

The Office of Energy Efficiency of Natural Resources Canada strengthens and expands Canada's commitment to energy efficiency in order to help address the challenges of climate change.

Canada<sup>!</sup>